



**Supplementary
Operating Manual
BOAT TRAILER**

Table of Contents

1. Tips for buying a boat trailer	3
1.1. Slip vehicle or certified boat trailer?	3
1.2. The type of boat	3
1.3. The weight of the boat	3
1.4. The length of the boat	3
2. Proper adjustment of the boat trailer	4
2.1. Adjusting the bow support	4
2.2. Adjusting the height-adjustable keel roller(s) and cross member with keel roller	4
2.3. Adjusting the boat pads and double rollers	5
2.4. Adjusting the light carrier	5-6
2.5. Adjusting the inflatable boat pads	6
2.6. Adjusting the sailing boat pads	6
3. Operating the slip mechanism	7
3.1. Slipping away	7
3.2. Slipping on	7

1. Tips for buying a boat trailer

You need to keep four important aspects in mind before buying a boat trailer in order to make an optimal choice for your boat.

1.1. Slip vehicle or certified boat trailer?

Slip vehicle: It has no certification and hence, it is not permitted to be driven on public roads. It is meant only for transport on private or non-public roads.

Certified boat trailer: With this, you have the option of transporting the boat even on public roads at the desired location.

There are several types available with COC documents.

1.2. The type of boat

In order to make the appropriate choice of the trailer, you must know the type of your boat. Our range of products includes motor boat trailers, inflatable boat trailers and sailing boat trailers.

1.3. The weight of the boat

The weight of the boat is a very important aspect in order to choose the appropriate maximum permissible total weight. This means that the self weight of the trailer + weight of the boat + fuel + equipment should not exceed this weight.

1.4. The length of the boat

Even the total length of the boat is an important factor that affects your choice of the appropriate trailer.



2. Proper adjustment of the boat trailer

In order to be able to use your trailer optimally, some one-time adjustments need to be done when loading the boat for the first time. If necessary, you may adjust the position of the axles.



Adjusting the axle position should be done only by a specialised workshop!

2.1. Adjusting the bow support

(1)

The bow support must be adjusted to the shape of the boat's bow. This is why it can be adjusted as required. While adjusting it, you need to pay attention to the support load (maximum permissible support loads of the ramp and trailer coupling).

We recommend: The load on the trailer coupling should be half of or lie in the upper one third of the maximum permissible load of the trailer, which improves the handling of your trailer while driving.

2.2. Adjusting the height-adjustable keel roller(s)(2) and cross member with keel roller(3)

You must ensure that the load of the boat is distributed uniformly on the keel rollers and pads available. This is why the boat should run on each roller in order to relieve the hull and to facilitate loading and unloading.

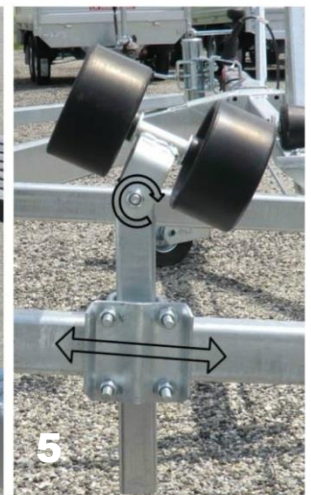
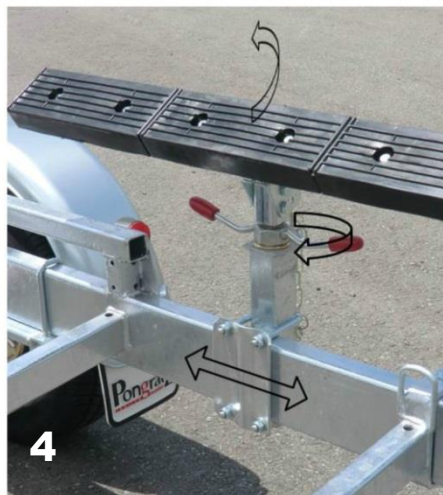
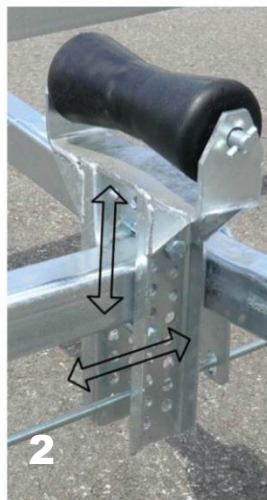
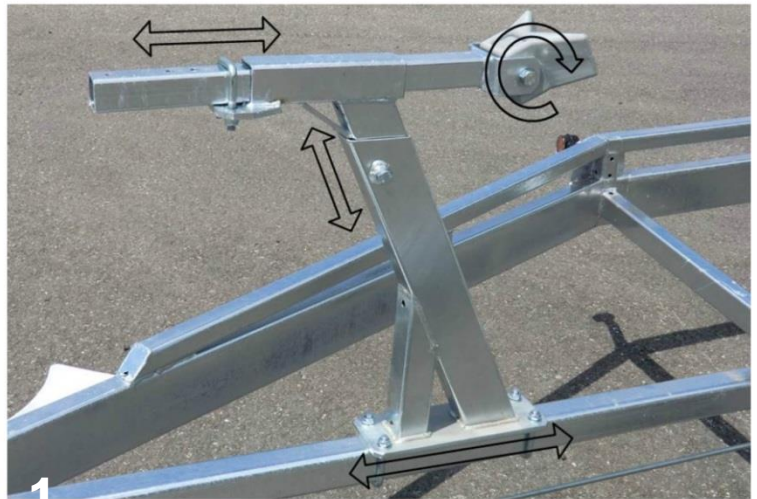

2. Proper adjustment of the boat trailer

2.3. Adjusting the boat pads (4) and double rollers (5)

In order to support the boat on its trailer, the boat pads and double rollers, if available, must be adjusted with respect to the height and angle. This adjustment must be identical (symmetric) on both sides. These components should not lift the boat from the keel rollers under any circumstances!

2.4. Adjusting the light carrier

If necessary, you have the option of extending the theoretical loading surface by pulling out the light carrier. Please note that this length depends on the model. Please enquire with the dealer or the manufacturer for special trailers.

Light carrier maximum extension length ($L_{max.}$)

<i>PBA U (Not braked)</i>	<i>PBA G (Braked)</i>	<i>PBA T (Tandem)</i>
PBA 500 U: 815 mm	PBA 750 G: 700 mm	PBA 1600 T: 965 mm
PBA 500 U-S: 815 mm	PBA 1000 G: 965 mm	PBA 2000 T: 965 mm
PBA 750 U: 700 mm	PBA 1300 G: 965 mm	PBA 2600 T: 965 mm *
PBA 750 U-S: 700 mm	PBA 1500 G: 965 mm	PBA 2600 T: 1465mm
	PBA 1800 G: 965 mm	PBA 3000 T: 965 mm *
		PBA 3500 T: 965 mm *
		PBA 3000 T-2: 1465mm
		PBA 3500 T-2: 1465mm

*Old design until 2015

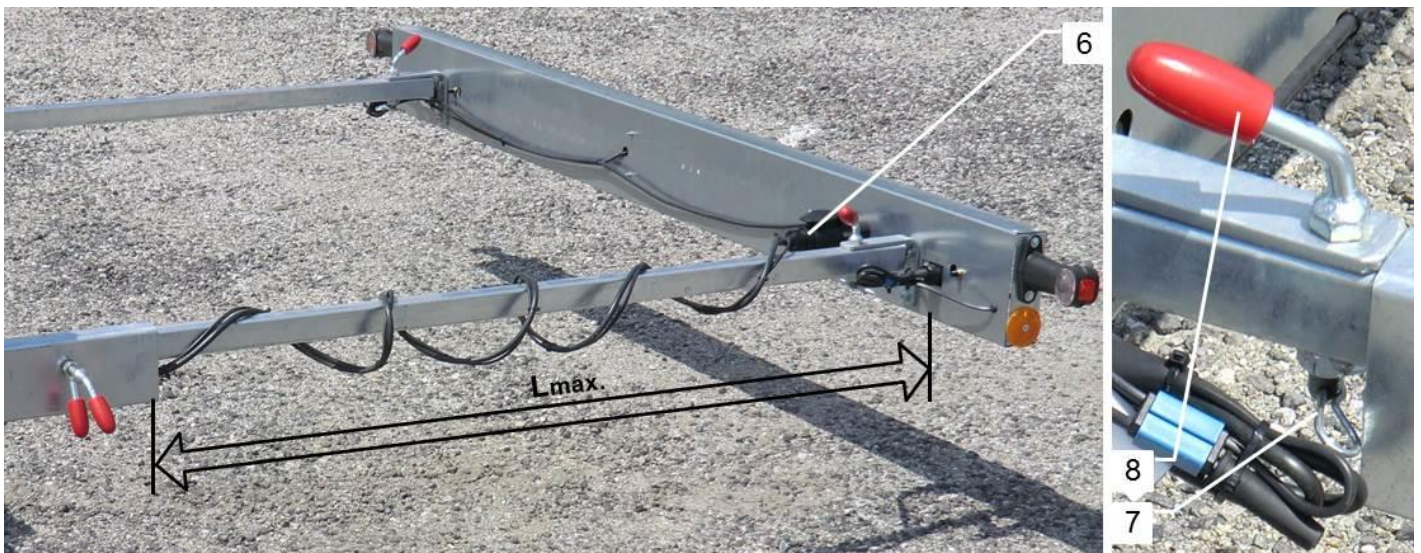

In order to protect the light from ingress of water while loading and unloading the boat, the light carrier must be disassembled!



2. Proper adjustment of the boat trailer

Disassembling the light carrier:

1. Remove the light plug (6).
2. Open and remove the safety splint (7) at the bottom of the handle screws.
3. Remove the screws of the handle (8) and ensure that the light carrier does not fall down on the ground while doing so.
4. To reinstall the light carrier →, carry out the steps in reverse order.

2.5. Adjusting the inflatable boat pads

The inflatable boat pads must be adjusted in such a manner with respect to the width, height and angle that the boat gets supported. You must ensure that these pads do not lift the boat from the keel rollers. If necessary, the height of the keel rollers must be adjusted accordingly.



2.6. Adjusting the sailing boat pads

You must ensure that the pads are adjusted with respect to height and angle in such a manner that the keel of the sailing boat sits properly on the wooden support of the trailer.



3. Operating the slip mechanism

3.1. Slipping away

1. Remove the light carrier. (refer to the disassembly of the light carrier:)
2. Remove all safety elements (lashing strap etc.) from the trailer.
3. Fix the boat to the base and place the fender on the boat.
4. Lift the boat motor.
5. Move the trailer backwards into the water max. up to the edge of the wheel rim.
6. Pull the hand brake.
7. Let the boat into the water.

3.2. Slipping on

1. Lift the boat motor.
2. Move the trailer backwards into the water max. up to the edge of the wheel rim.
3. Pull the stern of the boat up to the farthest rollers at the back and fix the winch hook.
4. Both the vehicle and the trailer must have the brakes engaged.
5. Pull the boat with the winch.
6. Insert the light carrier again and secure it. (refer to the disassembly of the light carrier:)



Pongratz

1st Edition 01/2017

Pongratz Trailer-Group GmbH

An der Bundesstraße 34, A-8772 Traboch
Tel. +43 3843/26033-0, Fax DW 40
office@pongraztrailers.com
www.pongraztrailers.com